



COMPANY PROFILE

We continuously grow as the most dynamic company in providing our expert services in the industry for building owners like you.

COMPANAY OVERVIEW

Doing things different

“

Top notch specialized commercial building facility management.

”

First things first. If you want to secure your customers' safety while enjoying the most of your facility, you've come to t the right place. We, Tri Asia pay attention down to the smallest details because we promise a service that is trouble-free all the time. We ensure your facility will leave a lasting impression on your customers when it comes to building management, your facilities, sustainability, and operations. We will work for tenant retention for you to achieve your much desired positive outcome.

We continuously grow as the most dynamic company in providing our expert services in the industry for building owners like you. Your facility's maintenance is vital, so we make sure we will get everything covered including:

- Roofing
- Waterproofing
- Painting
- Toilet & plumbing
- Flooring
- Groundwork
- Dooring system



We are a team of tradespeople with dedication, in-depth knowledge, and years of experience working for the same goal: EXCELLENCE

EXCELLENCE IN QUALITY

SUSTAINABLE VISION



Our Vision

Tri Asia operates with excellence in quality and workmanship in mind and heart. We envision a future of being recognized as the leading service provider in Building Facility Management that speaks of integrity and excellence in each project we do.

Our Mission

As a specialized provider of Commercial Building Facility Management services, we aim to design, construct, as well as maintain your working environment in the most exceptional and cost-effective way. At Tri Asia, we operate with dedication and expertise in all facets of interior and exterior building maintenance from groundwork to plumbing, roofing, waterproofing, flooring, and electrical works, dooring system for commercial properties in Malaysia and the Asian Market.

SAFETY & QUALITY

CORE VALUES

Our Company's Core Values:

At Tria Asia, we adhere to our mission in order to fulfill our vision. Every member of our staff is committed to ensuring we conduct our business under the same core values unique from the rest of the competition.

- **Work Ethics** – We do things right because that's the way it's supposed to be. We work hard with great dedication...that's how we want to leave our mark.
- **Communication** – Professionals in words and deeds. Tell us your concerns and special requests, and we are ready to listen carefully. We take your concerns and needs into account so we can address these issues appropriately. Your input is highly valued! We welcome comments and suggestions as these can improve our services even more.
- **Accountability** – We are accountable for all your building maintenance needs, and we have the initiative in doing every measure necessary just to keep your property in tip-top condition. We don't think twice when a problem is brought to our attention. Your problem is our problem, and we will resolve them for you.
- **Excellence** – Our staff who conducts themselves with professionalism and pro-active approach all the time. This attitude is evident in the way we organize, plan, and execute our plans with the right tools, equipment, and products to address an emergency or during our daily routines.
- **Workmanship** – Our existence is defined by our workmanship honed by our years of experience, proper training, and certification to ensure we will meet your needs- our valued client. You can expect consistency from us in providing and maintaining a clean, well-functioning physical environment of your building.
- **Improvement** – We don't settle for less, so we seek new ways...better ways of accomplishing our responsibilities and promise to your clients.
- **Safety and Quality** – We have high regard for safety and quality. Our staff is adequately trained to be wear appropriate clothing and able to handle equipment necessary to ensure safety while working. We continuously strive to learn, use, and operate safely using state of the art equipment as well as products. Tri Asia ensures every service provider follows the same practices so we can achieve customer satisfaction all the time- anything less is unacceptable.
- **Responsible Stewardship** – We will take care of your building maintenance for its optimum value over a long period of time. From our evaluation process to the selection of vendors, products, and outsources we use, we will ensure everything will provide the same quality and values that benefit your building.



FOR YOUR COMMERCIAL BUILDING

OUR PRODUCTS & SERVICES

Serving Malaysia and the Asian market, our commercial building facility management inclusive of plumbing, general electrical works , groundwork, painting, waterproofing, roofing, flooring, dooring system, general electrical work & ventilation system. You can find no substitute for our expertise as we provide the best.



Building Maintenance

The extensive experience of our team of experts is first class in their respective fields including solutions for commercial building exterior maintenance. The diverse and competitive market of commercial properties is crucial, so we understand your need to optimize yours. Ensuring your building is properly maintained can yield higher returns on rentals and ultimately great income.

We are a team of building maintenance providers with broad experience in the fields of:

- Construction
- Trade (automation, fire, electrical, and HVAC)
- Building technology
- Engineering

Piping and Plumbing

Our crew of professional plumbers is familiar with all the aspects of the piping and plumbing trade. Just leave your piping and plumbing issue to us, and we will solve it.

Aside from our standard piping and plumbing services, you may also take full advantage of our specialized services including:

- Domestic Water System
- Sanitary Drainages, Waste, and Ventilation Systems
- Water Heater System
- Plumbing Fixtures and Equipment
- Storm Drainage System
- Backflow Prevention
- Grease / Oil / Solids Interceptors
- Acid Drains, Waste, and Vent Systems
- Fire Lines, Sewer Systems, Sewer Lines

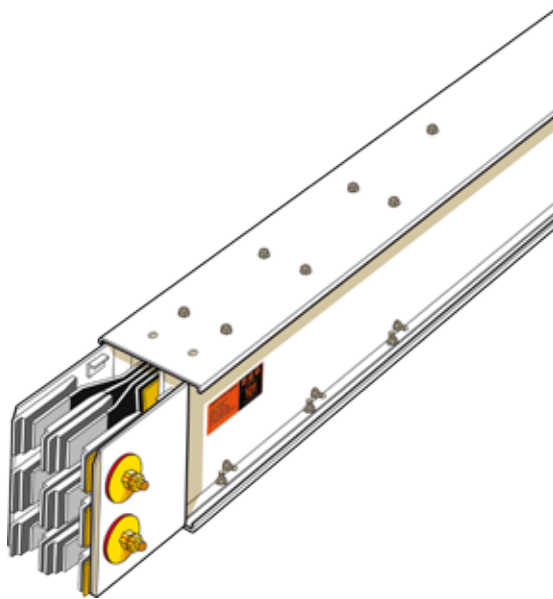

Electrical

We employ professional electrical engineers when it comes to the general electrical system's design and also construction for busduct, socket system, wiring, lighting, and cable system. It doesn't matter if you need our team for major construction or office fit, short or long timeline, Tri Asia will constantly communicate with you to ensure timely and satisfactory delivery.

Our electrical service entails but not limited to the following:

- Mechanical Electrical
- Distribution Switchboards
- HVAC Motor Control's Switchboard
- Control Panels
- Variable Speed Drive
- General (power & light)
- Building Management System
- Compliance with city and state Standards
- Compliance to Specifications of consultants
- Engineering & Design
- Testing & Commissioning

High-Quality Product Line of Busducts for Our Cable Management & Raised Floor Systems Service

We take pride in our cable management & raised floor systems using our own line of high-quality busducts. These are power distribution system for low voltage to your property's switchgear and its various loads. In case you don't know, busduct issues can lead to disastrous damages. Your building will suffer from extensive downtime, something that you don't want to happen... something that you can avoid.

Basic knowledge in the requirements needed when selecting busduct is not enough but an advantage. What you need is a reliable provider that will see to your needs from selection, by the time you order, and most especially during installation of your system.

Raised Floor

Don't worry if your office has no provision to rout underfloor wire. Fear not of tripping hazards or unattractive view of tangle computer cables, electrical cables, and telephone lines for raised floors. The superior strength and durability of these raised floors are perfect to withstand heavy traffic or usage. You can also choose from a selection of finishes to match your office's environment and design be it contemporary or modern.

Our high-quality Busducts has been dominating the Malaysian and Asian market for years now. Here at Tri Asia, we carry a popular product line of busducts manufactured using the latest technology, and in collaboration with leading industrial and engineering company in Japan.

These busducts come with a complete system consisting of plugin busducts, accessories, and feeder line each designed and engineered for high-rise buildings including:

- Condominiums
- Office Complex
- Commercial complex
- Institutions for Higher Learning
- Airport Terminals
- Hotels
- Military Base
- Hospitals
- Facilities with High Security

Cable Management

We got your back if you need enclosing of your electrical, cables, ancillary, telephone system service, as well as facilitating distribution if you own commercial or similar facilities. The safety of your employees, customers, and anyone who come in and out of your property is essential. You need to pass the current standards for a safe commercial environment seeming that most of these communications, accounting, and secretarial facilities use separate electric circuitry.

There is no reason why you cannot go for an open plan layout for your office or the latest trend in modern designs. Let us manage your cable systems for easier installation as well as usage flexibility. Whether you require floor trunking, vertical access, or junction bow, you can integrate our 3-group system in configuring the building's underfloor.

Do you have any inquiry for us?

Send in your email at kahweng.ho@triasia.com.my or give us a call at **03-5525 3212**

Schedule an appointment today!

PROVIDED WITH BROAD EXPERIENCE OUR PORTFOLIO

▼ Giant Hypermarket



▼ Guardian



◀ Jasons Food Hall

▼ Cold Storage





◀ HSBC Bank

▼ Evolve Mall



▲ Australia High Commissioner

◀ Teng Minimarket Centre (TMC)



TriAsia Engineering Sdn Bhd (1011698-A)

No 14-3, jalan Anggerik Vanilla R31/R,
Kota Kemuning,
40460 Shah Alam,
Selangor, Malaysia.

Tel: 03-5525 3212

Fax: 03-5525 3215

Email: kahweng.ho@triasia.com.my

Website: www.triasia.com.my